

GRANT

FORM
5565/5565-1

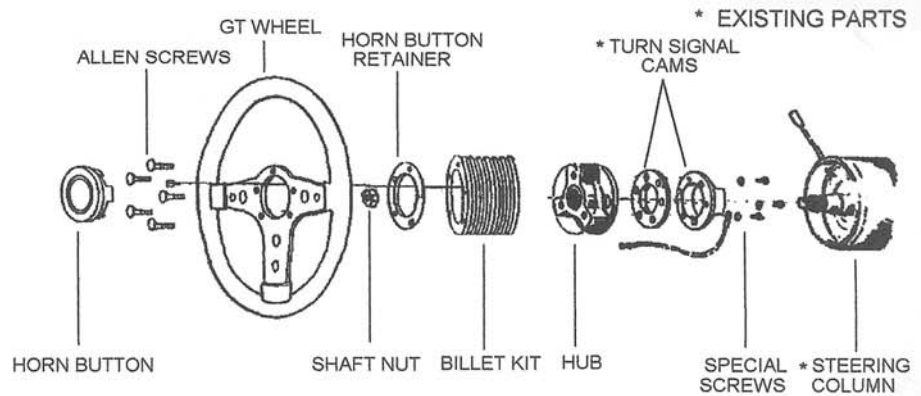

REMOVING ORIGINAL WHEEL

1. Point wheels straight ahead and disconnect battery or pull horn fuse before starting removal of the old wheel so horn won't short out and blow during installation.
2. Remove horn mechanism. This is normally done by one or more of the following steps:
 - a) Press down on horn cap or ring and turn.
 - b) Remove emblem cap from its snapped-in condition by grasping it and pulling toward you, or pry loose
 - c) Horn ring and emblem may be secured by screws which are concealed in rear side of wheel spokes.

If one of the above operations has not removed all of the horn parts, it will have exposed the remaining screws to permit easy removal of the balance of such parts.

3. Remove nut which holds wheel to shaft.
4. Mark shaft as to which is the top of the wheel.
5. With conventional puller, (or GRANT puller 5891), use the two tapped holes which you will find in the hub of old wheel to pull off the steering shaft.

If a puller is not available, you may improvise an efficient one to do the job. By drilling two holes of the proper size in a short steel bar and using two screws of the proper length, you can tighten them and pull the old wheel very easily.

PREPARATION TO INSTALL NEW WHEEL

Note: If your car has a wire coming from the center of the steering shaft, follow steps 6 & 7, then proceed to step 9.

If your car does not have center wire, proceed to step 8.

6. Remove the turn signal cam parts from the back of your old steering wheel and reinstall these on the back of custom hub using the special nylon screws furnished in kit. (The original screws will not fit).
7. Horn wire modification - cut contactor from end of wire coming from shaft, strip insulation back about 3/8". Slip plastic covered solderless connector furnished in kit over end of wire and crimp securely with pliers. Crimp terminal from wire provided in kit and strip insulation back about 3/8". Insert this end into solderless connector and crimp securely with pliers. Proceed to step 9.

8. 1971 and later cars refer to enclosed supplement for proper positioning of turn signal cam, then proceed to step 9 (not 13). All other vehicles proceed as follows:

Remove turn signal cam parts from back of old wheel and reinstall these on back of custom hub using the nylon screws furnished in kit. Under the head of the screw located at about 2 o'clock when viewed from the front, put the ring terminal of wire provided in kit and tighten screws.

9. Position hub on splined shaft, observing that arrow stamped on billet collar is located in accordance with the mark you made in step 4.
7. **Preparing wheel for installation**-Remove the five (5) allen screws securing wheel to GT adapter (GT adapter is not used with billet kit installation). Take wheel, horn button, retainer ring and any other components and transfer these to "billet" adapter noting that arrow stamped on collar is the top of the wheel. Reinstall screws securely, but leave horn button off at this time.
10. Connect the wire lead coming from kit to the center terminal on back of horn button. If your wheel had a grounding lead (from step 8) connect this wire to the remaining terminal on back of horn button.
11. Install horn button in center of wheel, reconnect battery or replace fuse, and enjoy your new GRANT wheel.

Our Limited Warranty

We warrant this product for ninety (90) days from the date of original purchase to be free from defects in materials and workmanship. If, during this period, the product fails under normal usage because of a manufacturing defect, then we will replace or repair the item. To obtain repair or replacement under the terms of this warranty, notify us at 615 Elca Lane, Suite C, Brownsville, TX 75821. Proof of purchase and date of purchase are required to validate warranty.

All implied warranties, including warranty of merchantability, are limited to this same ninety-day period from date of original purchase. We are not liable for any direct or consequential loss or property damage arising from any use of this product. This warranty gives you specific legal rights, and you may also have other rights which vary from state to state. Offer good in U.S.A. and Canada only.

IMPORTANT

FOR YOUR OWN SAFETY, DO **NOT** USE THIS WHEEL FOR ANY COMPETITIVE OR COMMERCIAL RACING PURPOSES: RACING DOES NOT CONSTITUTE NORMAL USAGE AND THEREFORE MAKES THIS WARRANTY VOID.

On The Web: www.grantproducts.com

Rev. 5/09 by JF

97527-05-01