

**NOT FOR USE ON AIRBAG
EQUIPPED VEHICLES**

GRANT

* EXISTING PARTS

FORM 5701

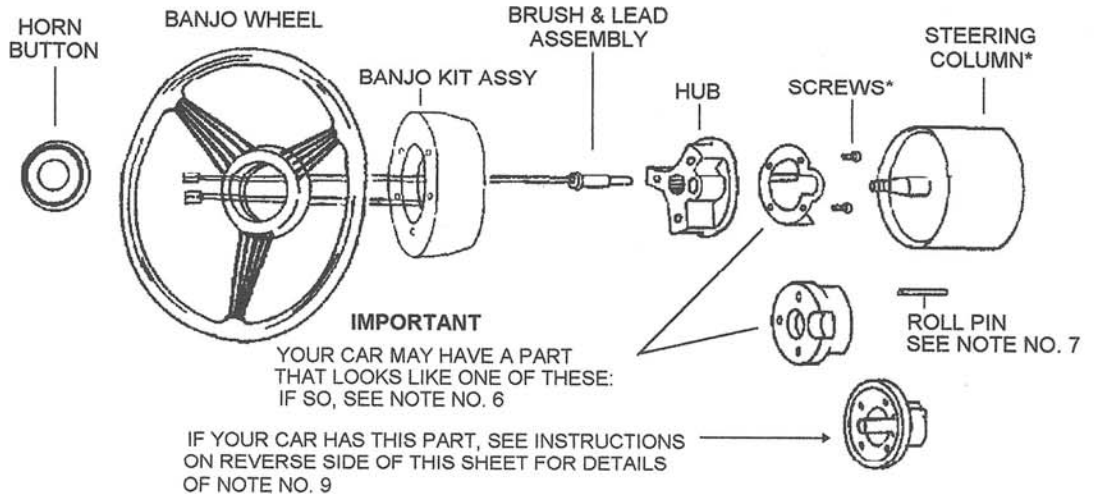

This GRANT Banjo Wheel Kit can only be used on a GRANT Banjo Wheel and is not for use on any other type of wheel or a competitor's product. It cannot be used in conjunction with our Vehicle Security System.

REMOVING ORIGINAL WHEEL

1. Point wheels straight ahead and disconnect battery or pull horn fuse before starting removal of the old wheel so horn won't short out and blow during installation
2. Remove horn mechanism. This is normally done by one or more of the following steps:
 - a) Press down on horn cap or ring and turn.
 - b) Remove emblem cap from its snapped-in condition by grasping it and pulling toward you, or pry loose.
 - c) Horn ring and emblem may be secured by screws which are concealed in rear side of wheel spokes.

If one of the above operations has not removed all of the horn parts, it will have exposed the remaining screws to permit easy removal of the balance of such parts.

3. Remove nut which holds wheel to shaft.
4. Mark shaft as to which is the top of the wheel.
5. With conventional puller, (or GRANT puller 5891), use the two tapped holes which you will find in the hub of old wheel to pull off the steering shaft.

If a puller is not available, you may improvise an efficient one to do the job. By drilling two holes of the proper size in a short steel bar and using two screws of the proper length, you can tighten them and pull the old wheel very easily.

PREPARING TO INSTALL NEW WHEEL

6. If there is a turn signal cancellation device, such as illustrated, attached to the back of your old wheel. Remove this part and reinstall it in the same position on the back side of custom hub.
7. If your old wheel has a pin inserted in the back side, note its location. You will find a roll pin furnished in your kit. Insert this pin in the back side of custom hub using the pin location of old wheel as a guide. Be sure slot in pin is facing in toward the center of hub.
8. Position hub on splined shaft, observing that "top" is located in accordance with the mark you made in step No. 4.

9. Position Banjo Kit assembly onto hub passing wire through feed hole. Be sure arrow stamped on assembly is at the top position. Install the three hex cap screws provided to hold assembly onto hub (under one of these bolts, position the eyelet on wire supplied with wheel to provide a good ground for the horn button) and tighten them to 10-12 ft/lbs. **NOTE:** Excessive torque will result in damage to the hub. Do not over tighten these bolts.
10. **Preparing wheel for installation:** Remove plastic horn button from wheel (it is easier to push out from the back side) then remove the trim ring surrounding this button by pulling up from the front. It fits very snugly, but will come out. Remove the five (5) allen screws securing wheel to GT adapter, which will not be used. Transfer wheel to Banjo Kit assembly on column noting that it is oriented correctly and reinstall the five screws securely.
11. Check to ensure that the wheel is in the proper position, and if correct, install the wheel retainer nut and tighten securely to 25-30 ft/lbs.
12. Reinstall trim ring into center of wheel. Connect the grounded wire lead to the outer terminal on back of horn button and the wire coming up from the custom hub to the center terminal. Push horn button into trim ring. Reconnect battery or replace horn fuse and enjoy your new GRANT Banjo Wheel.

Our Limited Warranty

We warrant this product for ninety (90) days from the date of original purchase to be free from defects in materials and workmanship. If, during this period, the product fails under normal usage because of a manufacturing defect, then we will replace or repair the item. To obtain repair or replacement under the terms of this warranty, notify us at 615 Elca Lane, Suite C, Brownsville, TX 75821. Proof of purchase and date of purchase are required to validate warranty.

All implied warranties, including warranty of merchantability, are limited to this same ninety-day period from date of original purchase. We are not liable for any direct or consequential loss or property damage arising from any use of this product. This warranty gives you specific legal rights, and you may also have other rights which vary from state to state. Offer good in U.S.A. and Canada only.

IMPORTANT

FOR YOUR OWN SAFETY, DO NOT USE THIS WHEEL FOR ANY COMPETITIVE OR COMMERCIAL RACING PURPOSES: RACING DOES NOT CONSTITUTE NORMAL USAGE AND THEREFORE MAKES THIS WARRANTY VOID.

On the Web: www.grantproducts.com

Rev. 05/09 by JF 97525-01-01